

NATR 6

Dimensions

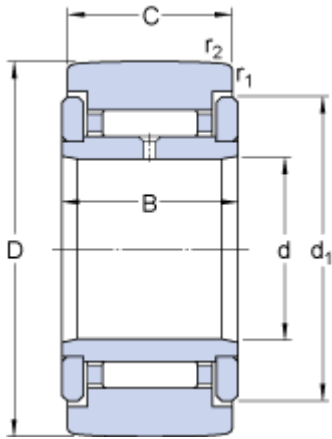

D		19	mm
d		6	mm
C		11	mm
B		12	mm
d ₁		15	mm
r _{1,2}	min.	0.15	mm

Calculation data

Basic dynamic load rating	C	3.5	kN
Basic load rating, static	C ₀	3.8	kN
Fatigue load limit	P _u	0.415	kN
Maximum static radial loads	F _r	3.8	kN
Maximum static radial loads	F _{0r}	5.5	kN
Limiting speed		5600	r/min

Mass

Mass support roller		0.02	kg
---------------------	--	------	----